

OFC040

# File Cabinet

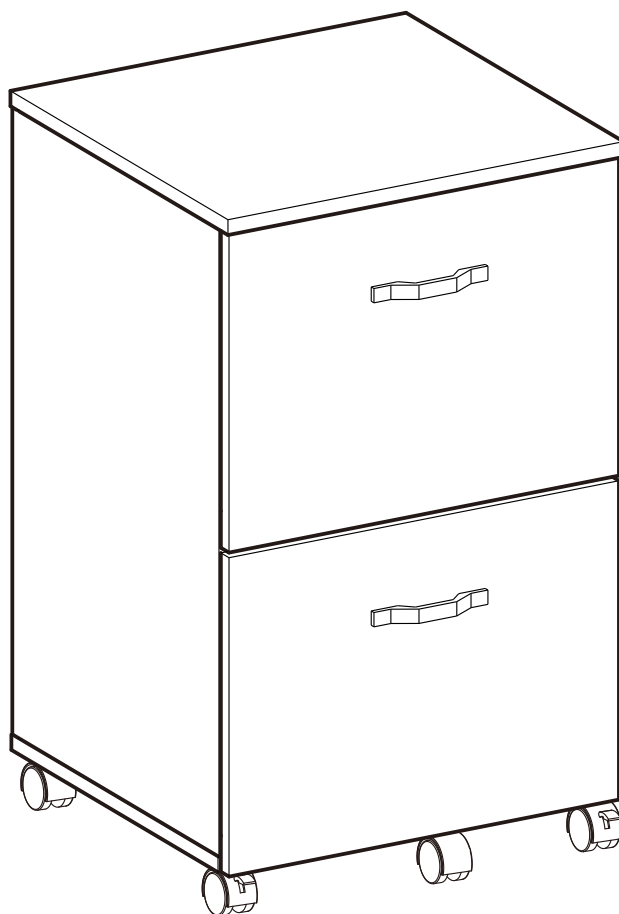

**VASAGLE**

by SONGMICS HOME

**A** × 1

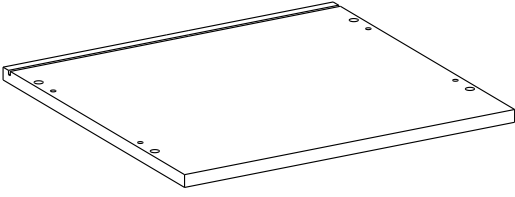

**B** × 1

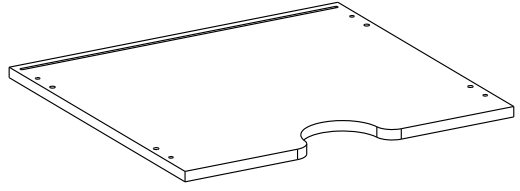

**C** × 1



**D** × 1

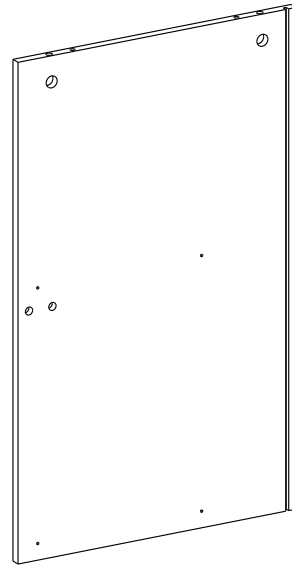

**E** × 1

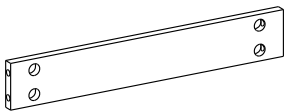

**F** × 1

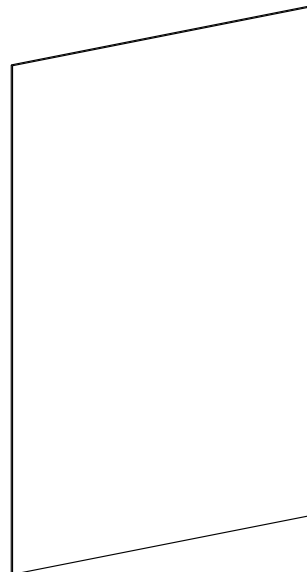

**G** × 1

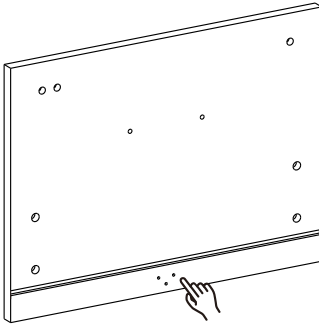

**H** × 2

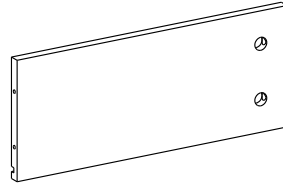

**I** × 2

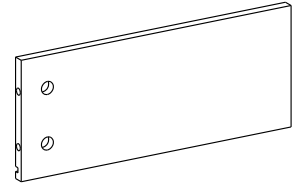

**J** × 2

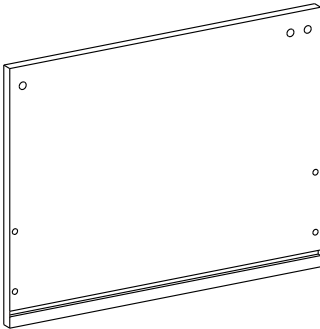

**K** × 2

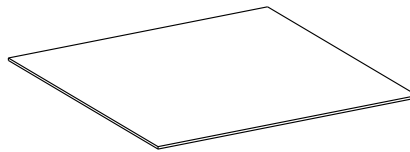

**L** × 4



**M** × 1

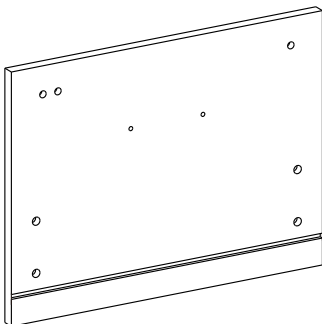

1 12+2

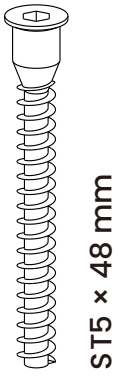

2 16+2



3 16+2

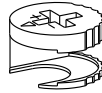

4 4+1

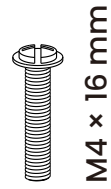

5 8+2



6 35+2



7 8+2



8 x 8

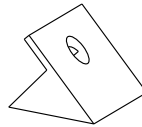

9 x 1

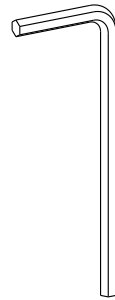

10 x 1

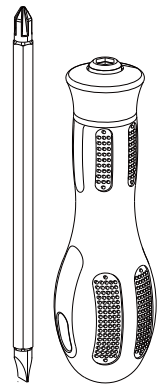

11 x 2

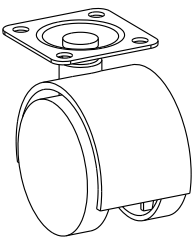

12 x 2

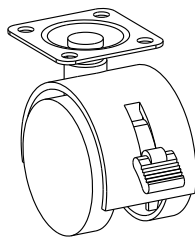

13 x 1

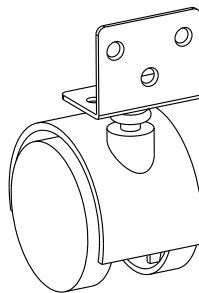

14 x 2



15 x 2

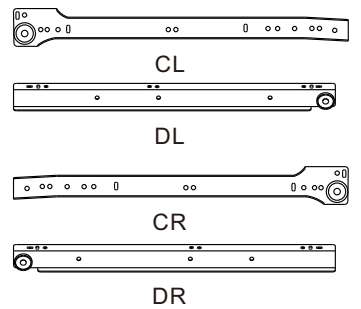

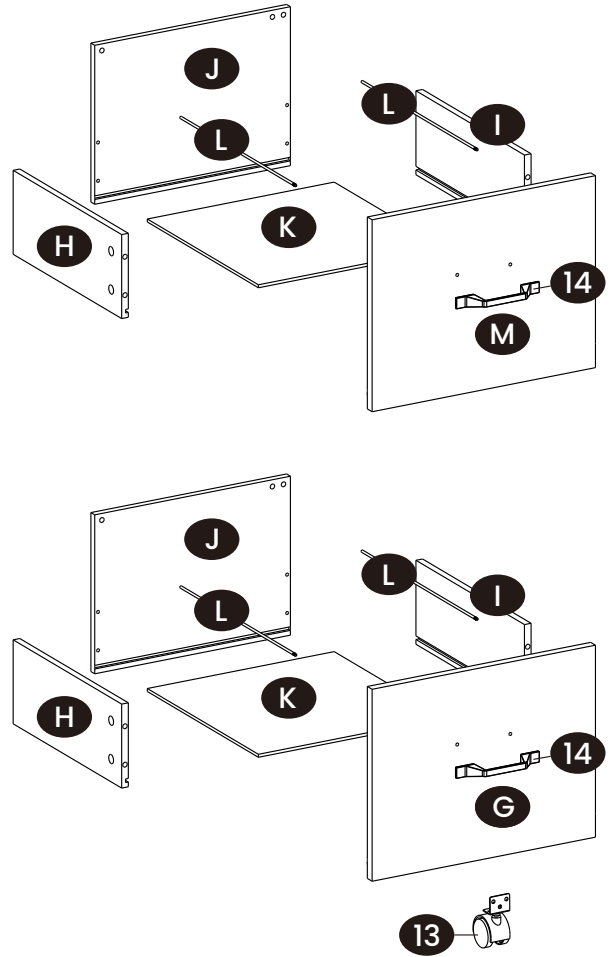
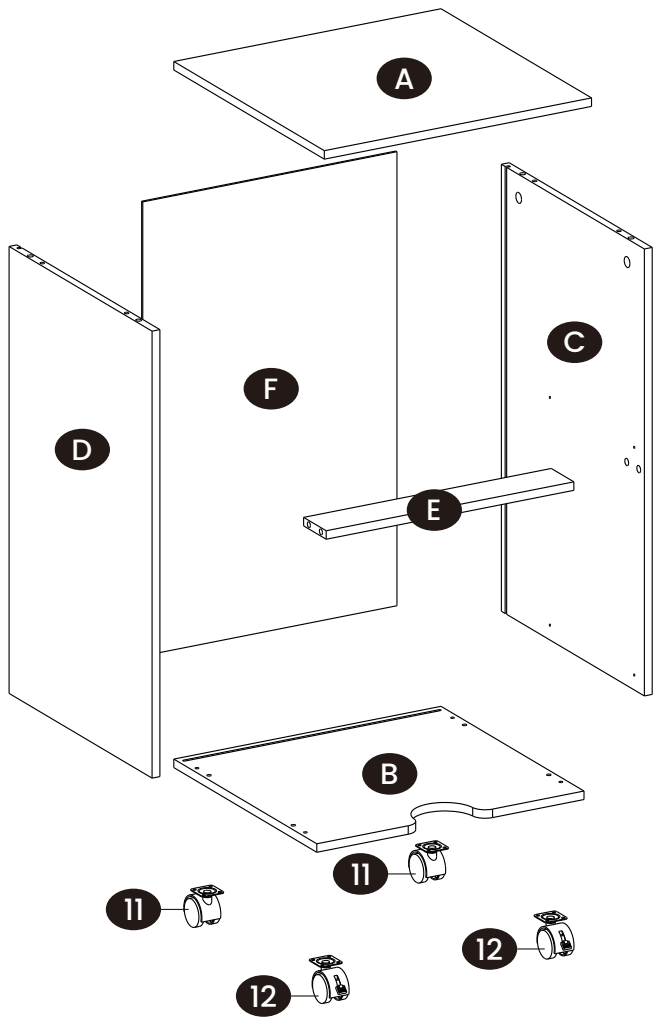

## Tools Required:

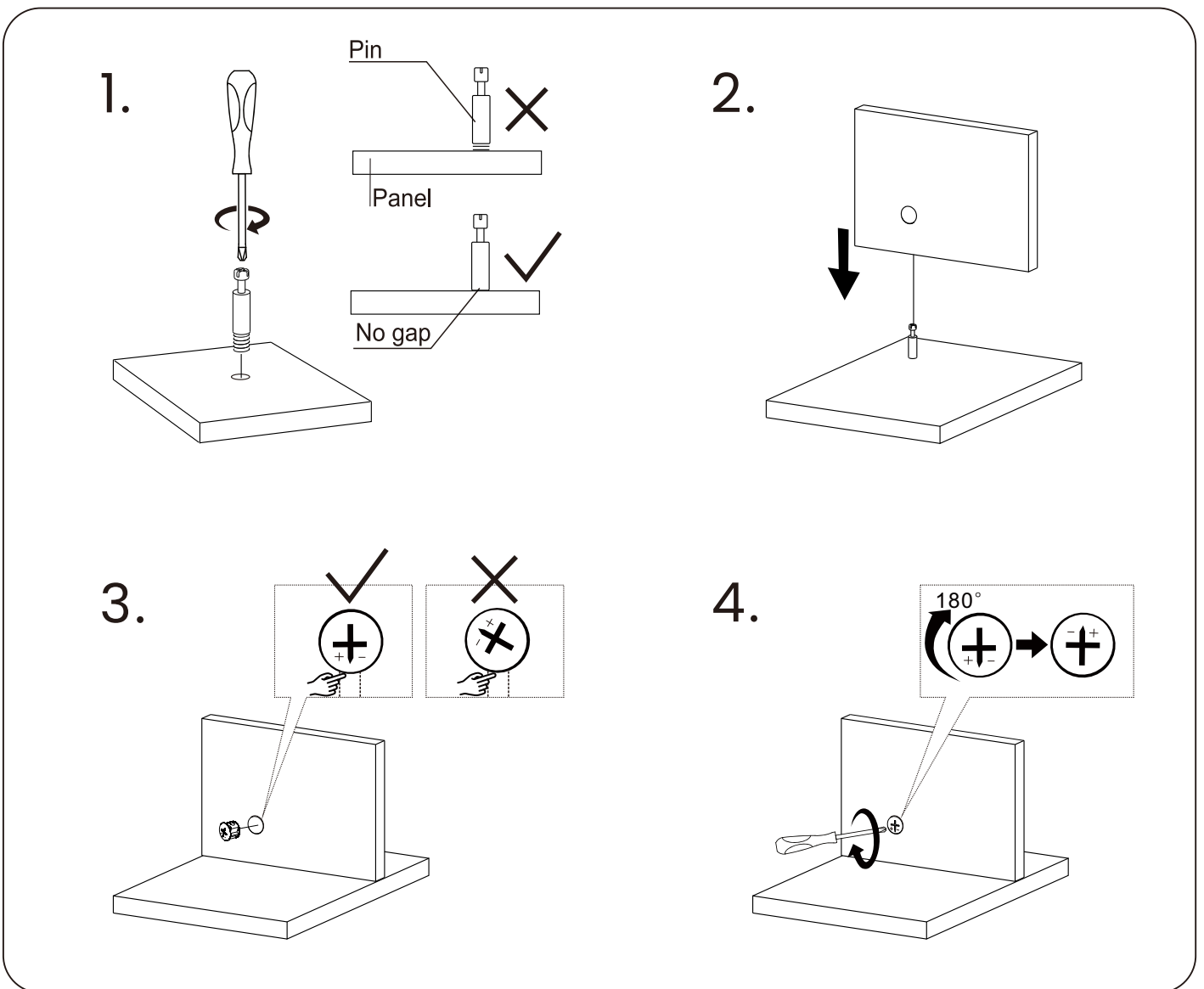
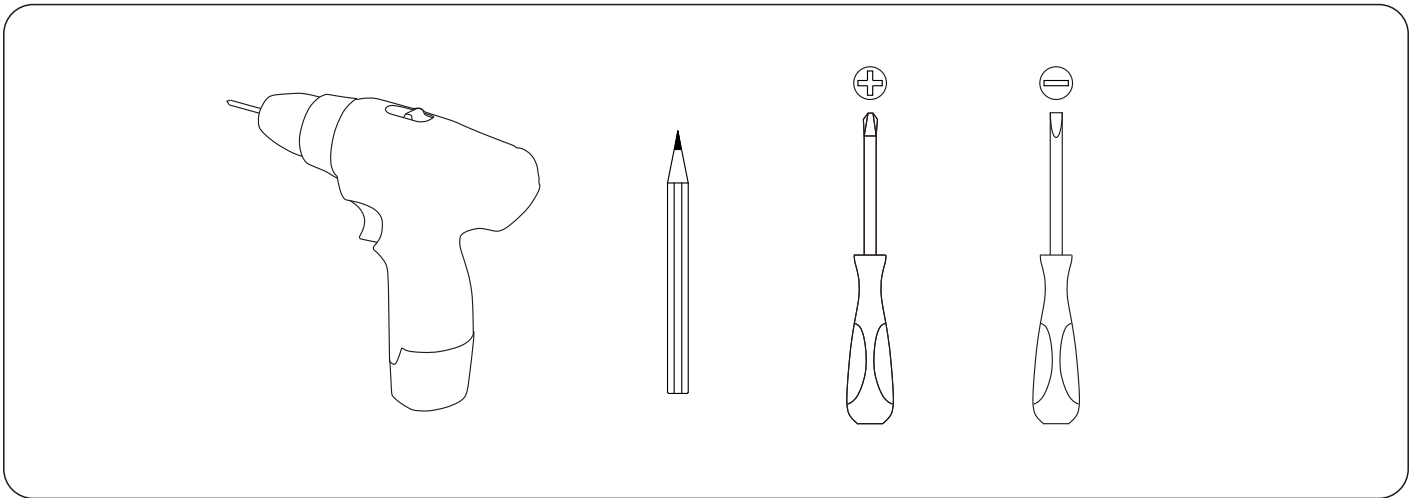

1

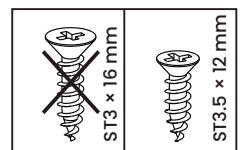
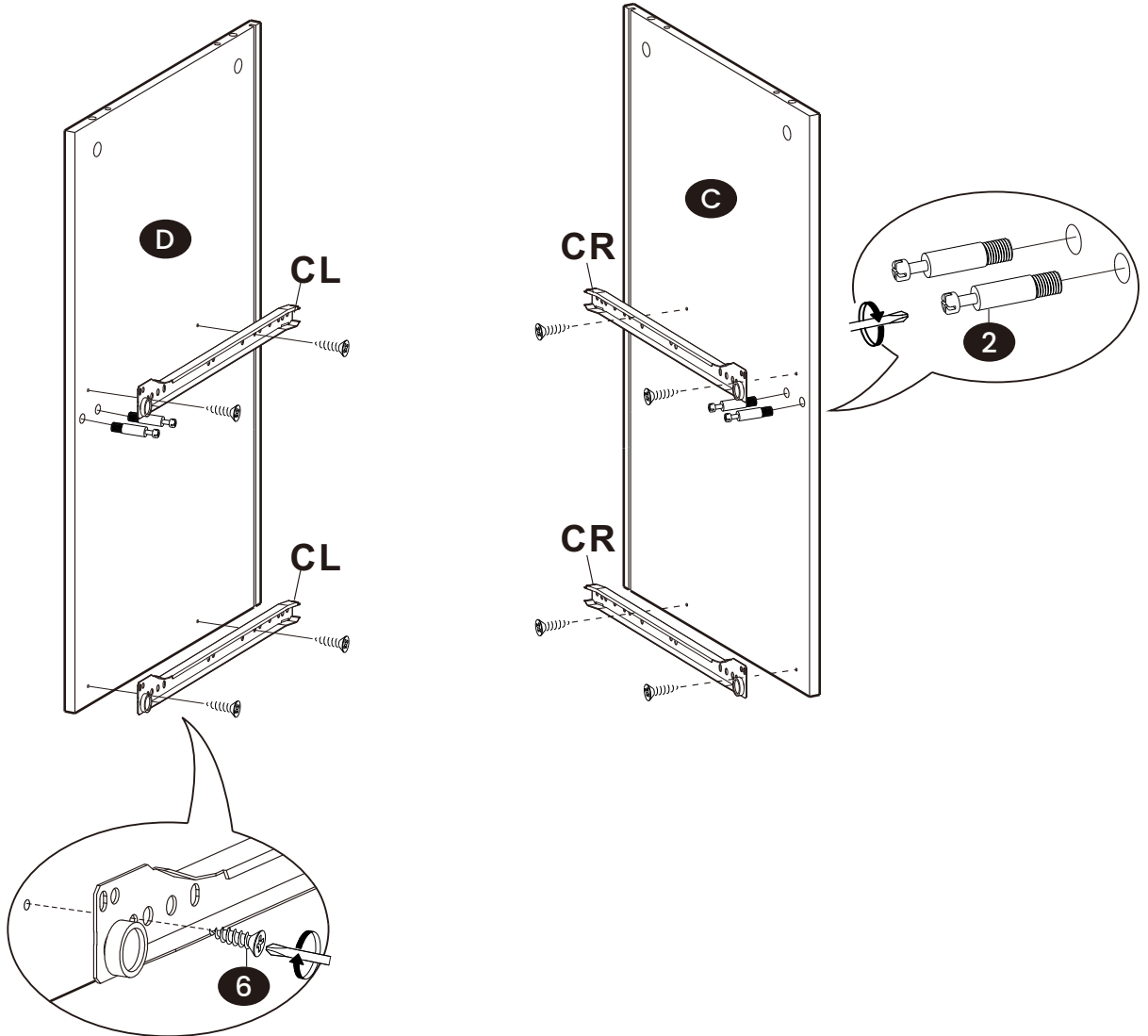
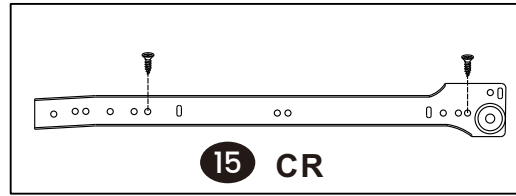
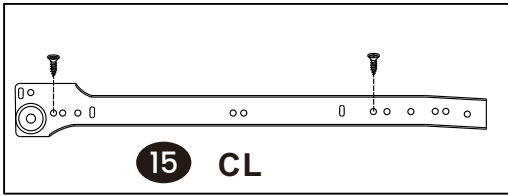

<b>2</b>		<b>x 4</b>	<b>6</b>		<b>x 8</b>
----------	---	------------	----------	---	------------

2

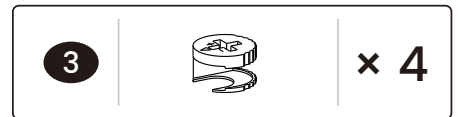

3

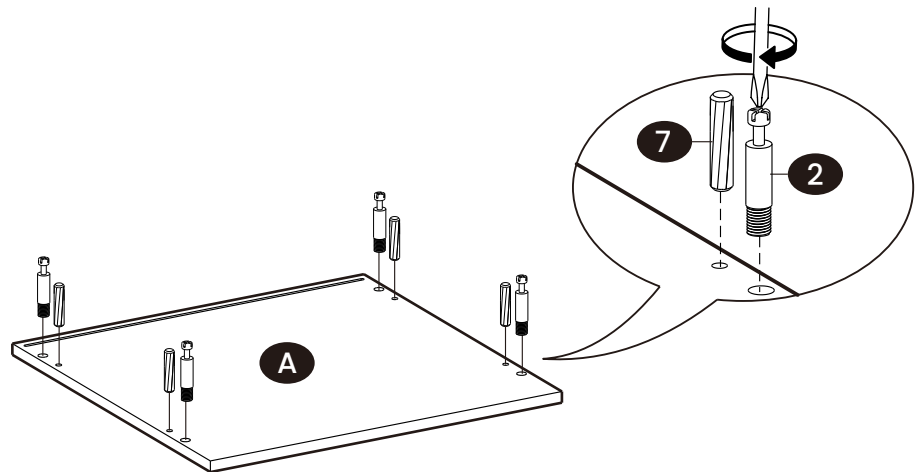

4

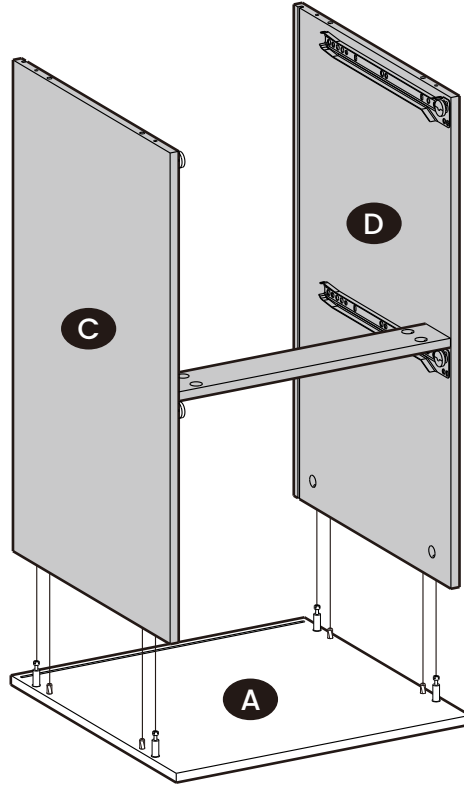

5

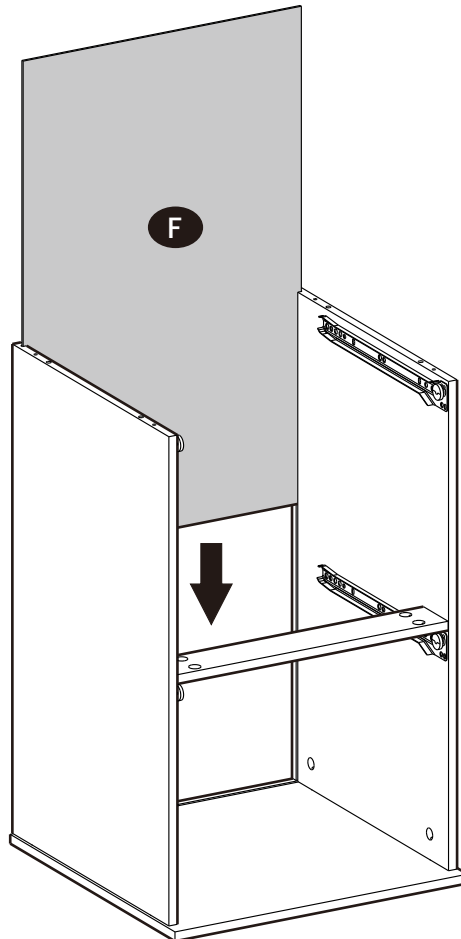

# 6

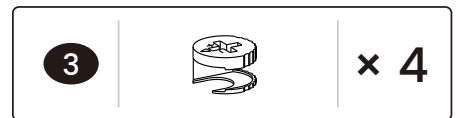
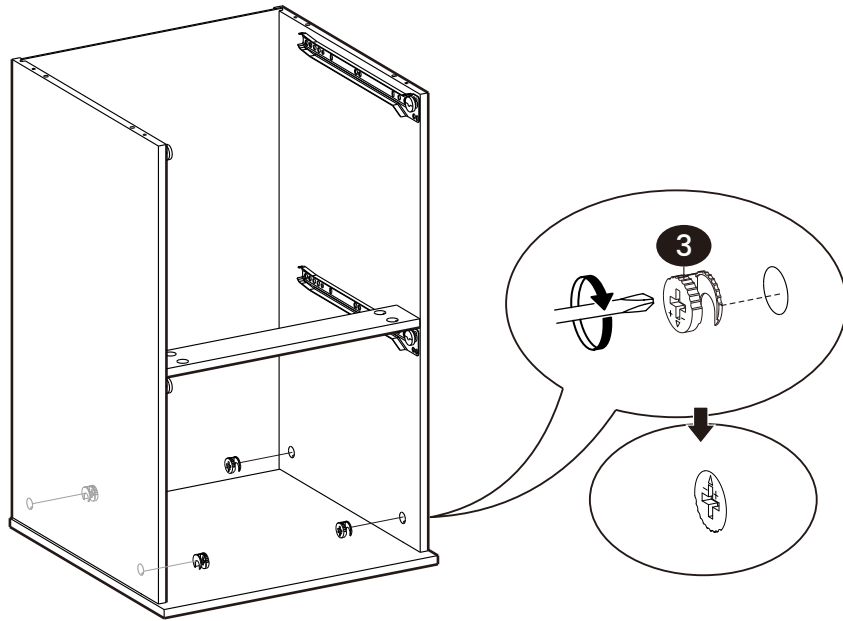

# 7

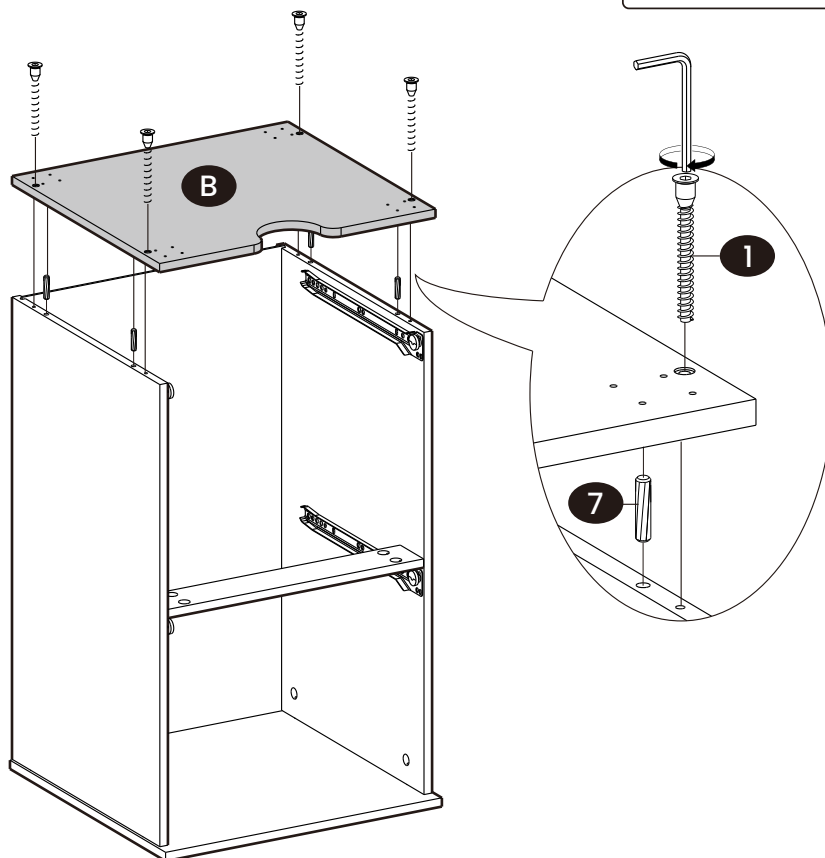

# 8

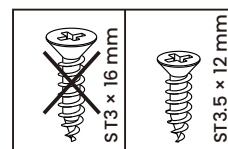
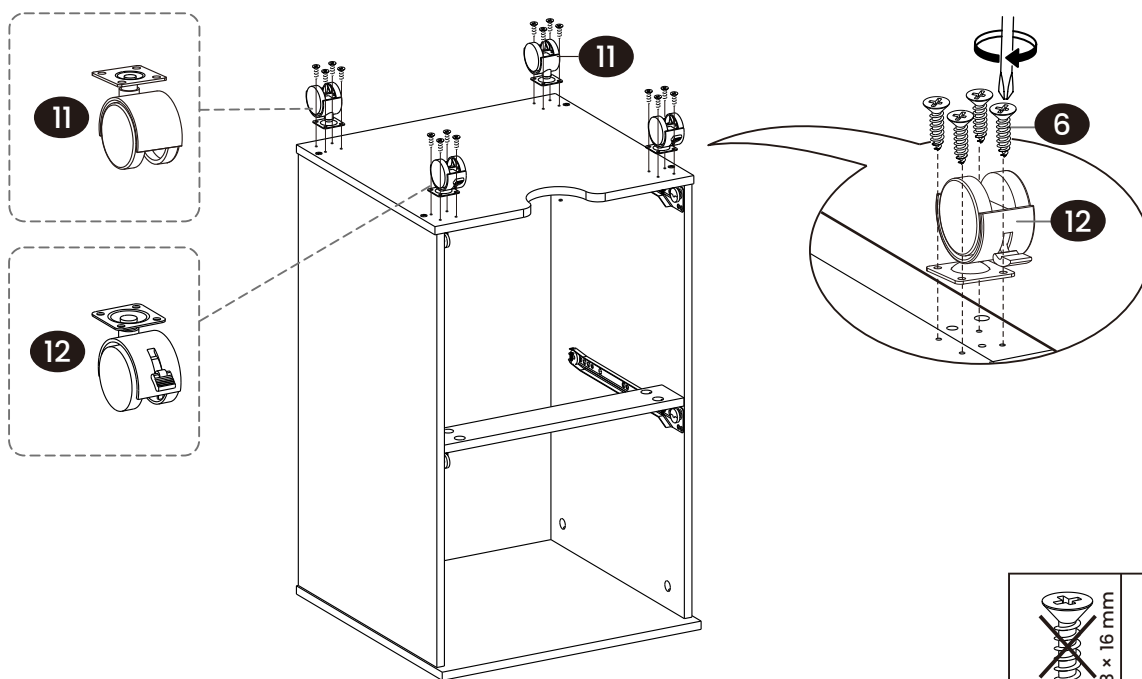

6		x 16	11		x 2	12		x 2
---	--	------	----	--	-----	----	--	-----

# 9

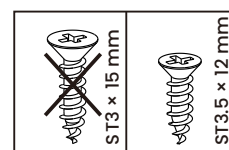
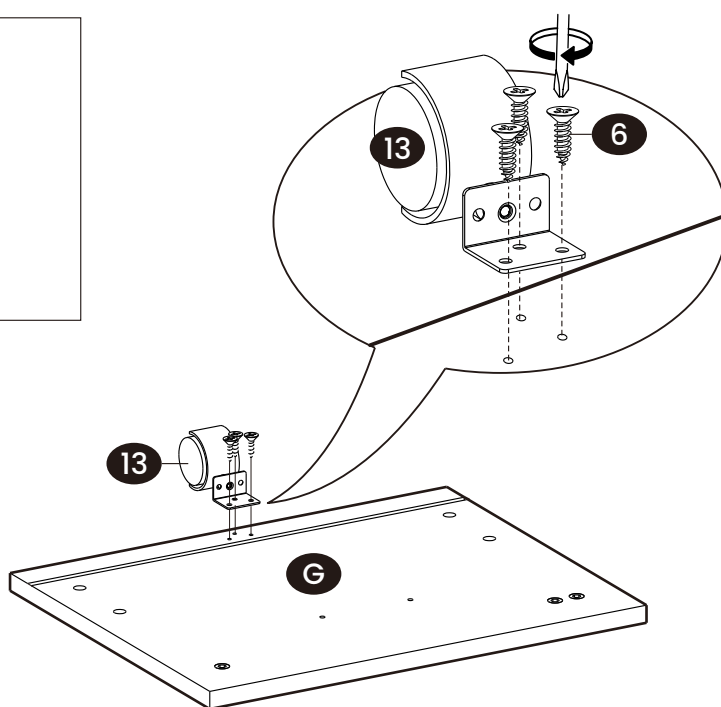
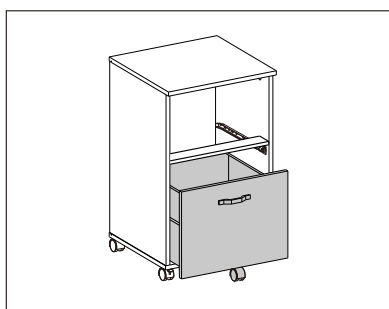

6		x 3	13		x 1
---	--	-----	----	--	-----

# 10

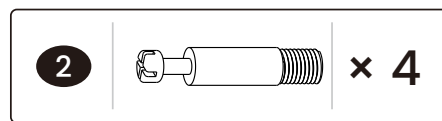
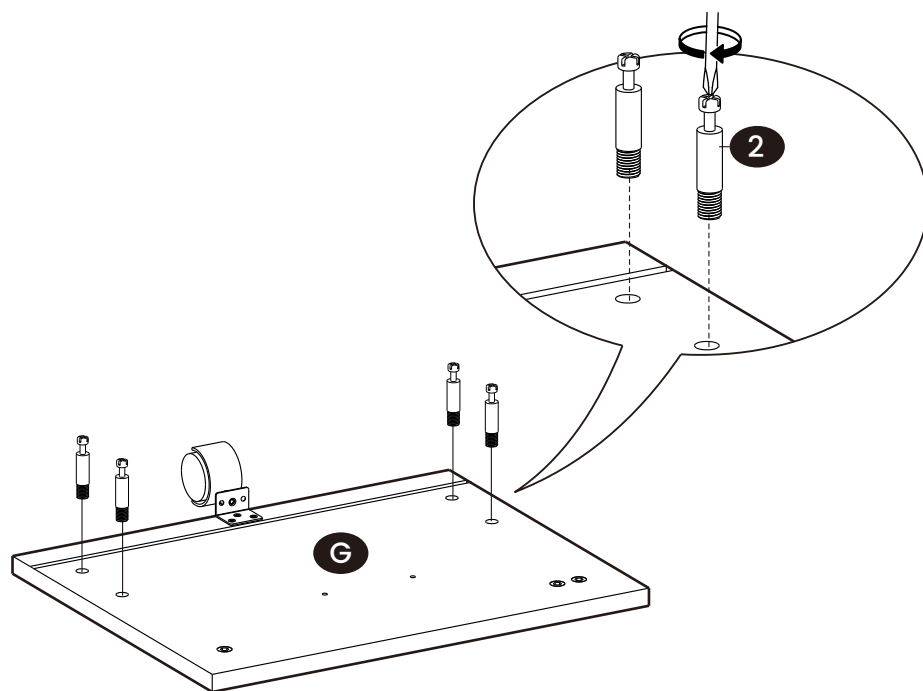

# 11

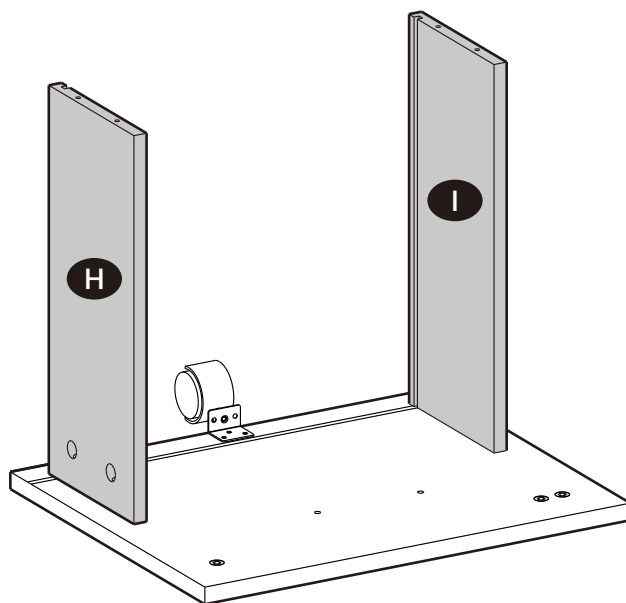

12

# 12

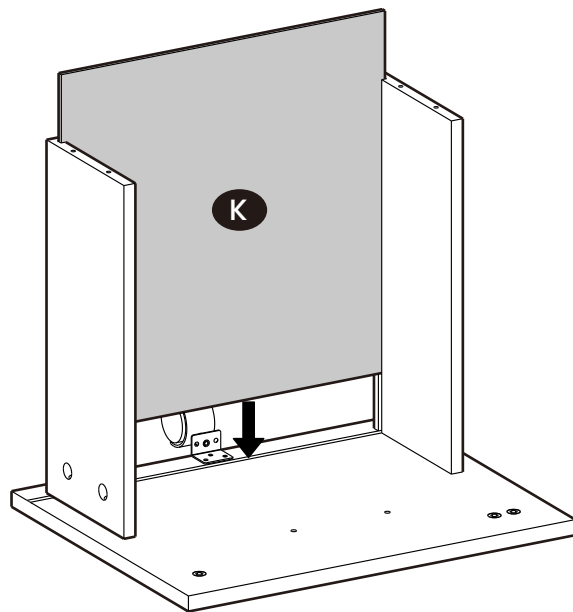

# 13

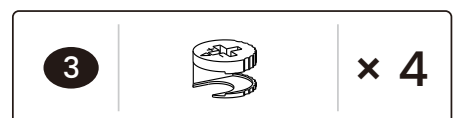
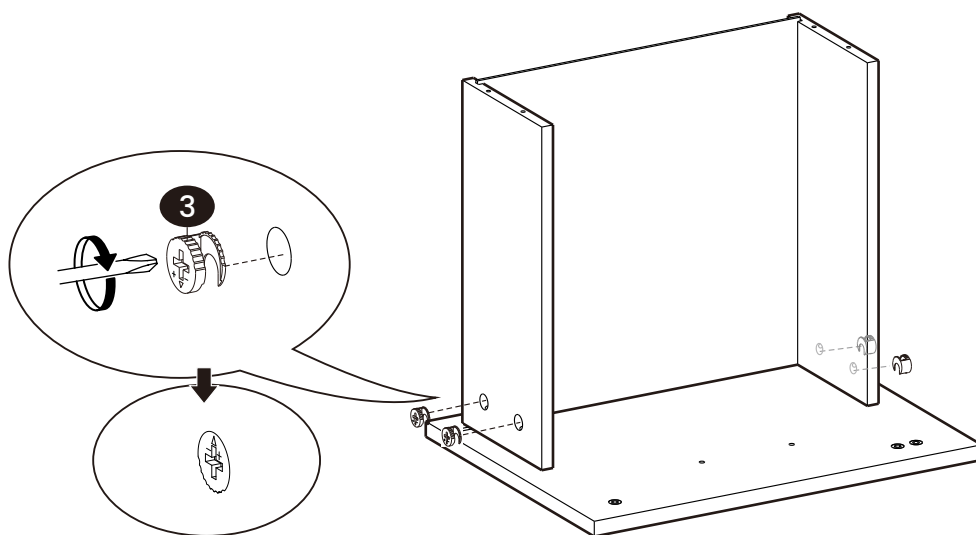

14

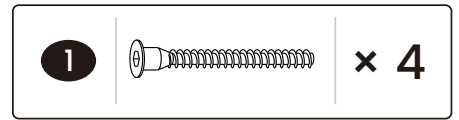
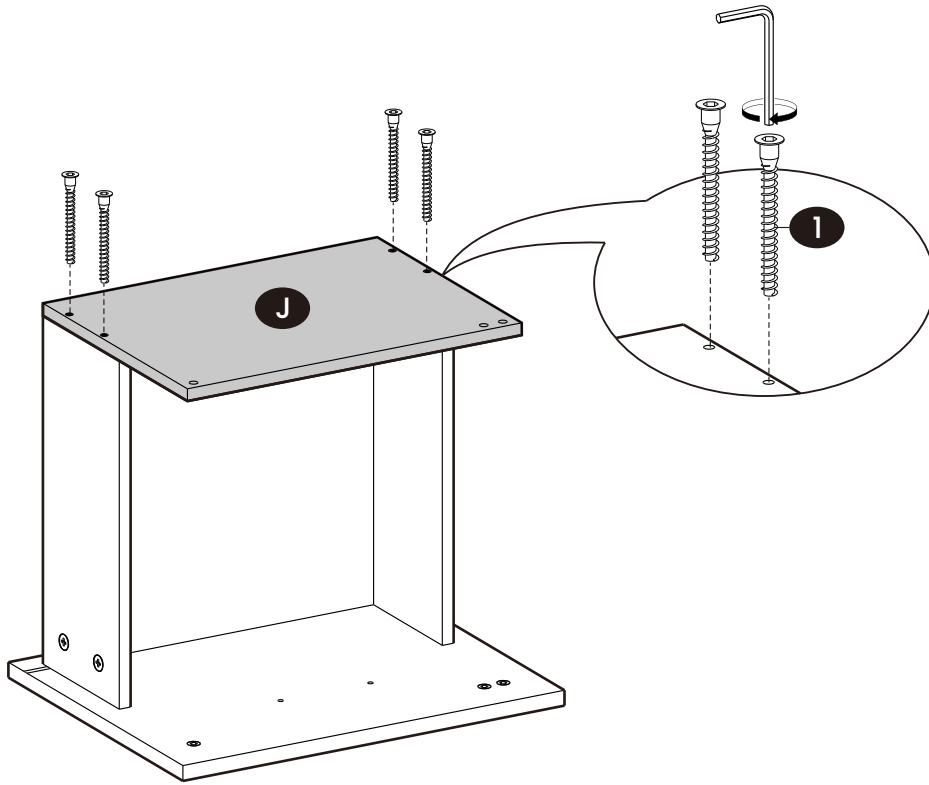

15

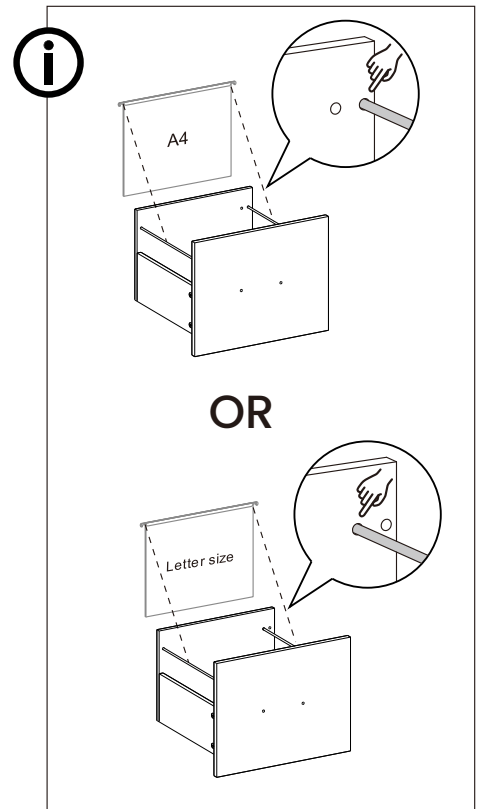
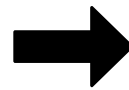
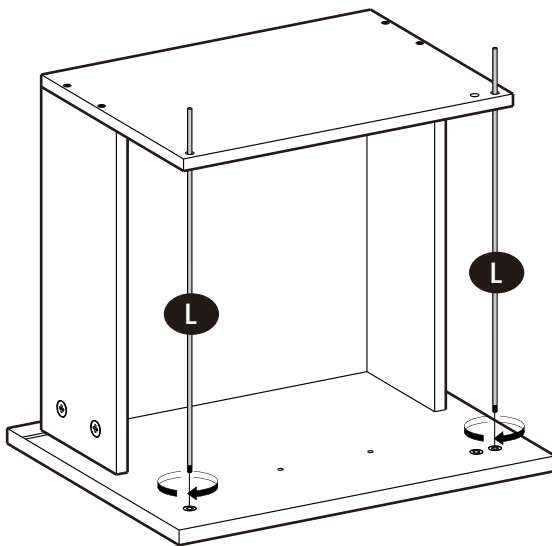

# 16

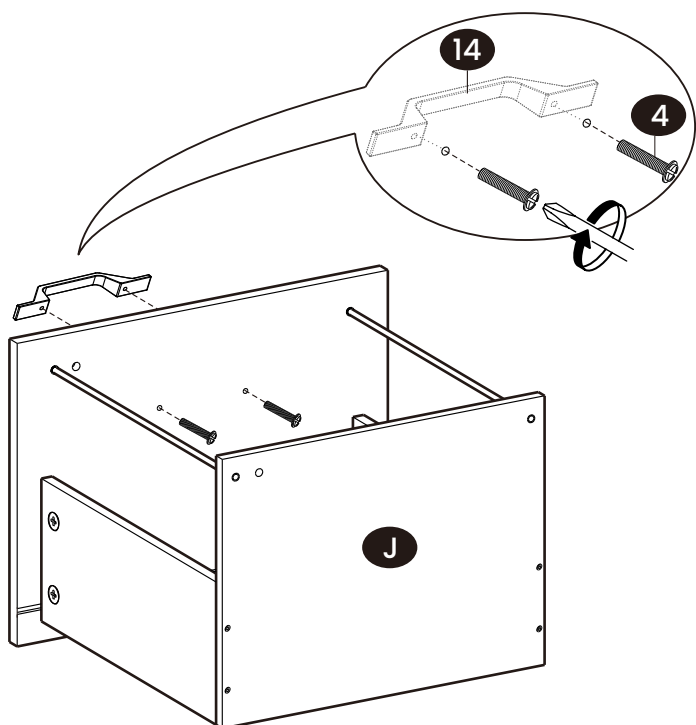

# 17

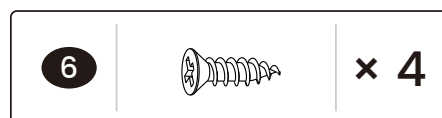
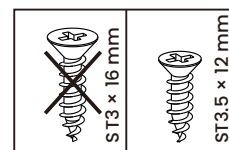
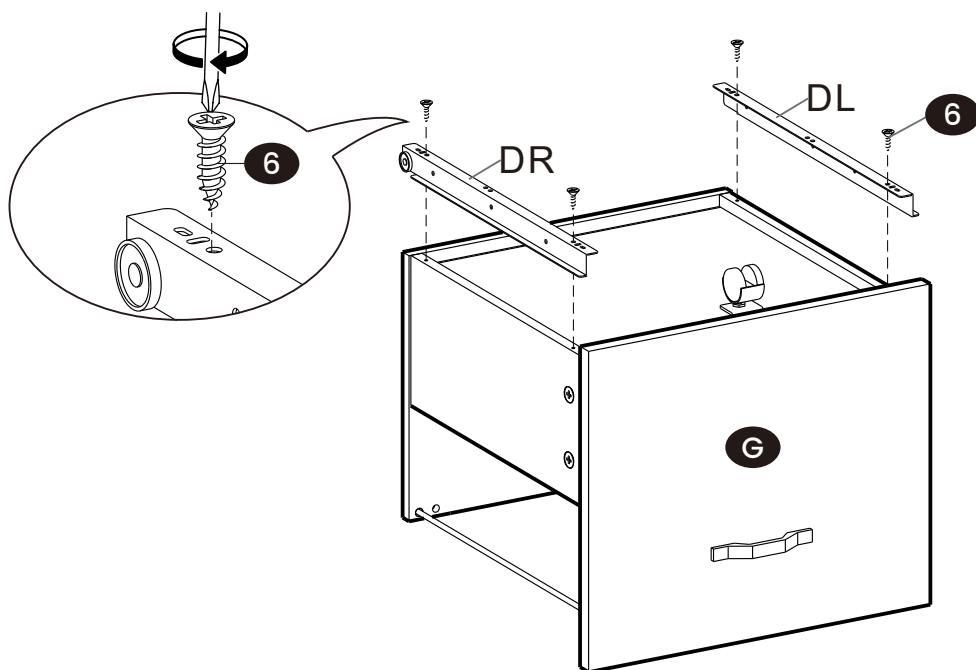
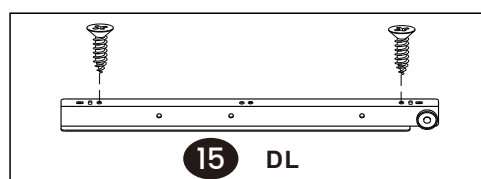
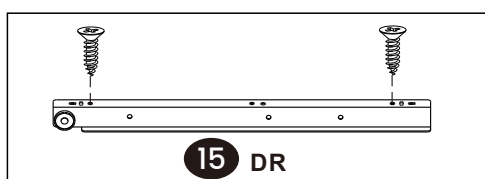

# 18

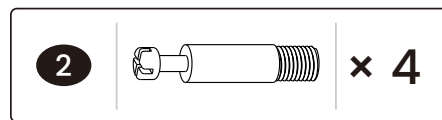
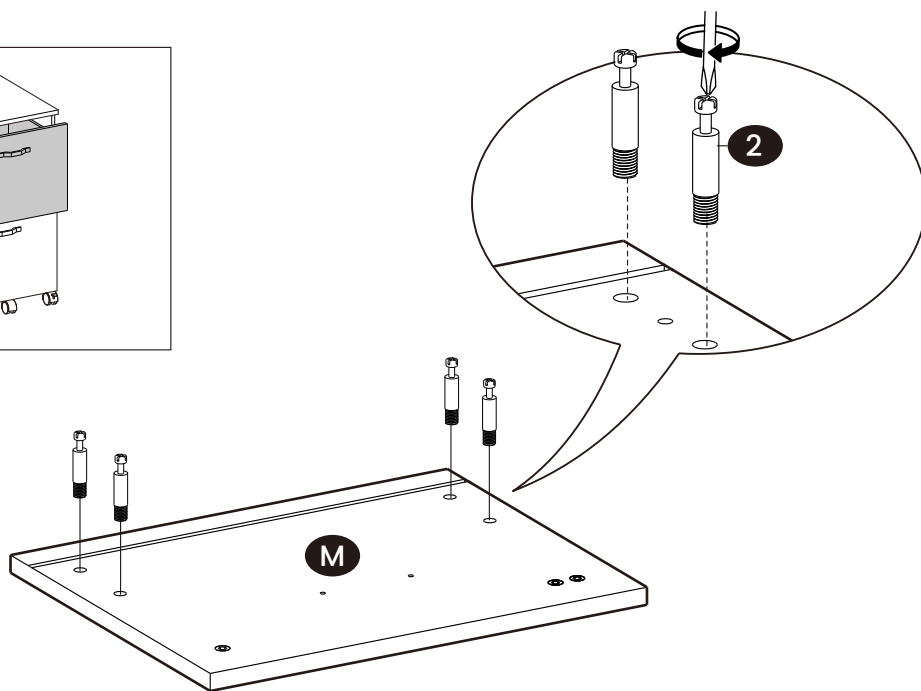
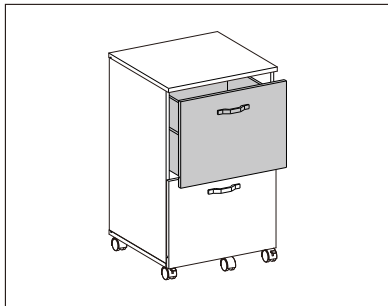

# 19

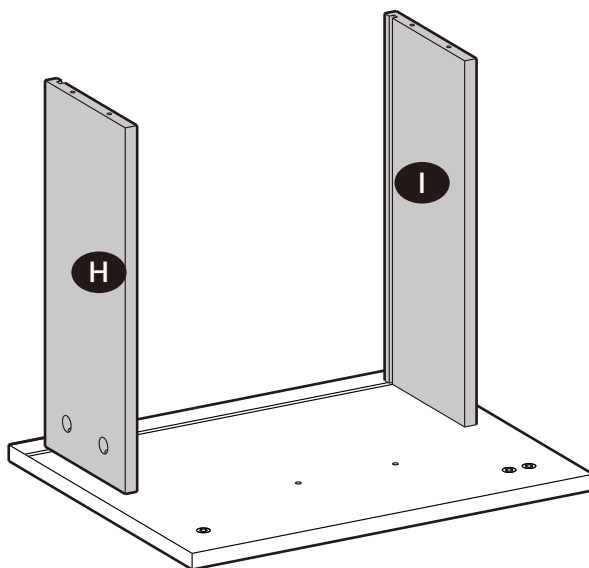

# 20

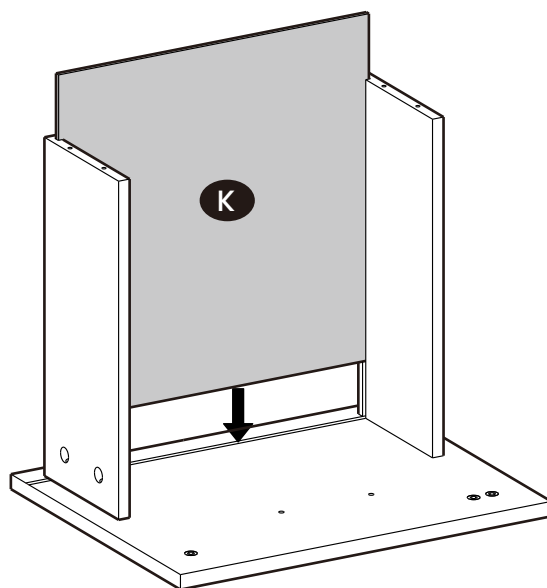

# 21

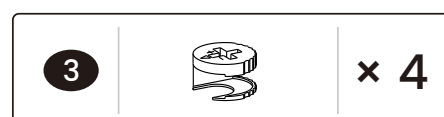
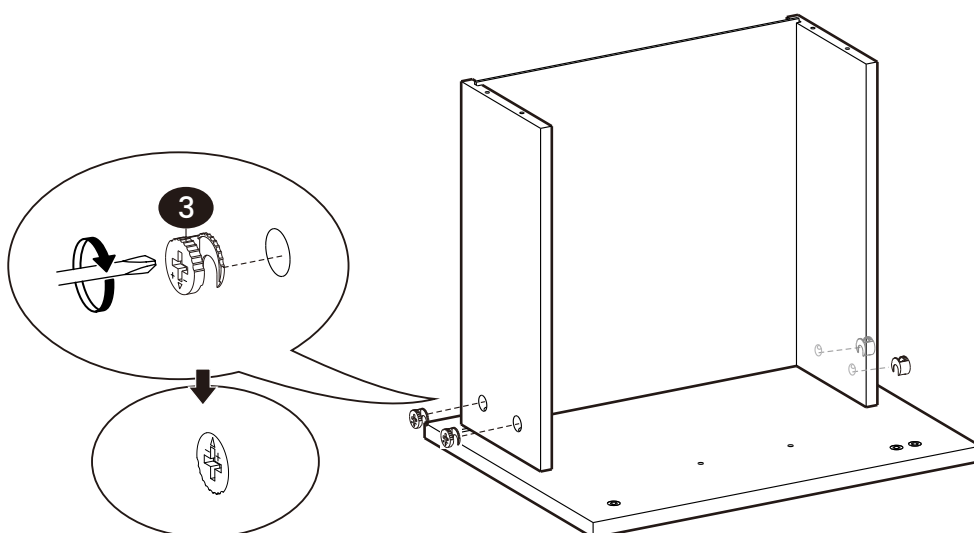

# 22

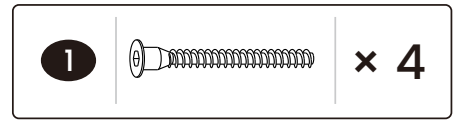
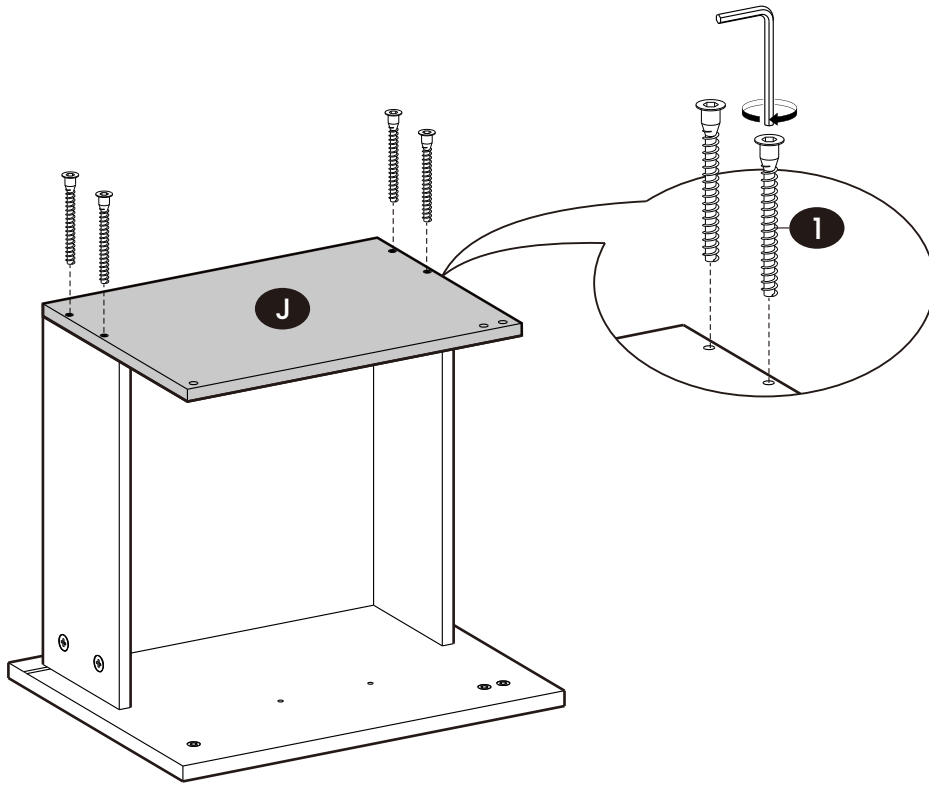

# 23

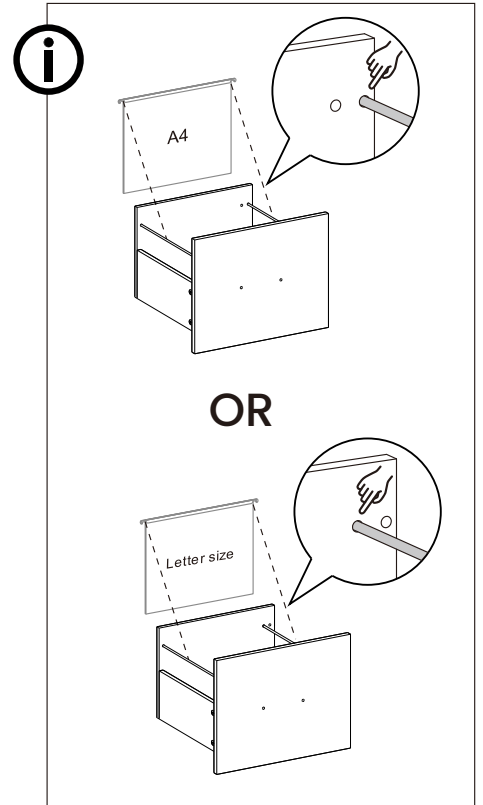
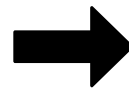
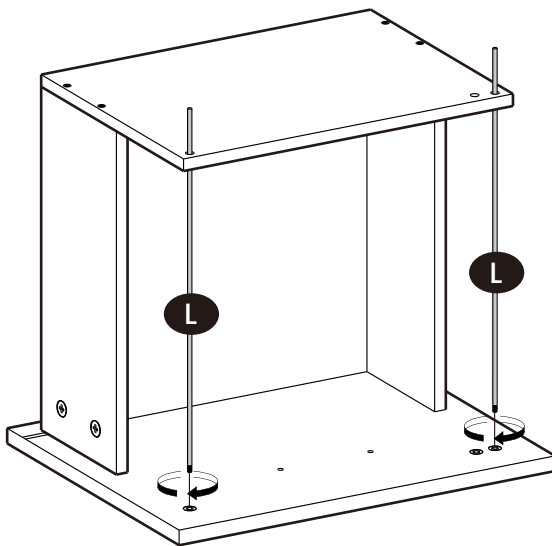

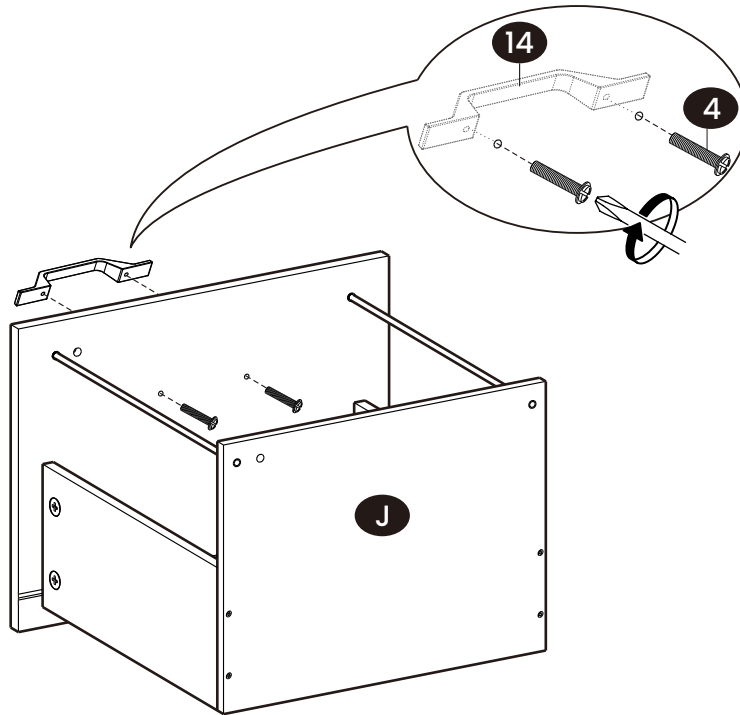

# 24

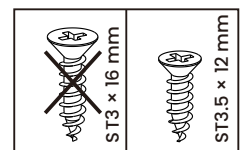
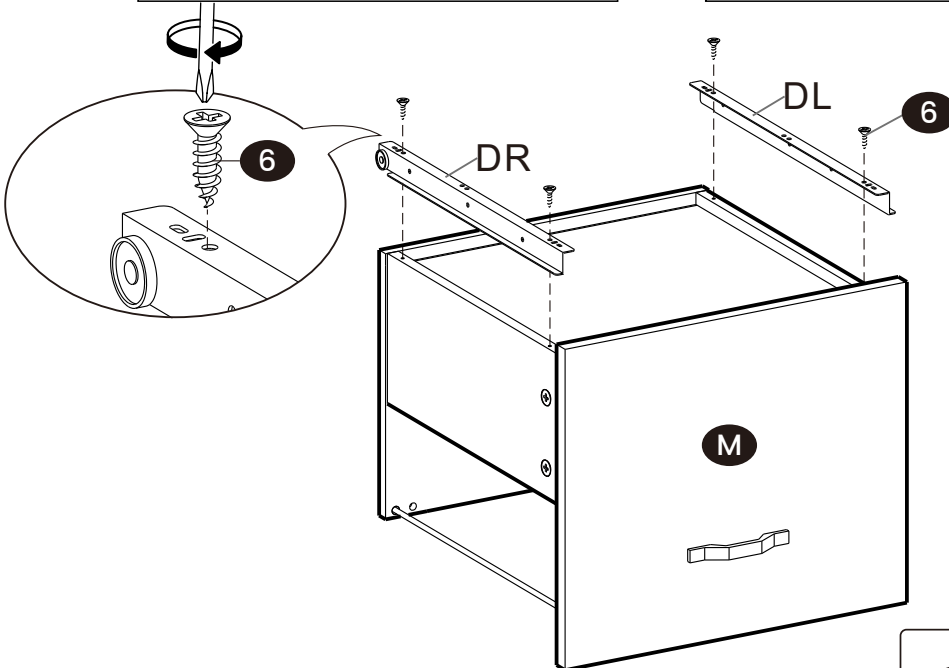
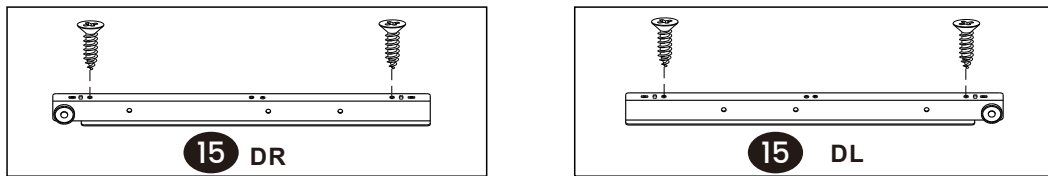

4		× 2	14		× 1
---	--	-----	----	--	-----

# 25



6		× 4
---	---	-----

# 26

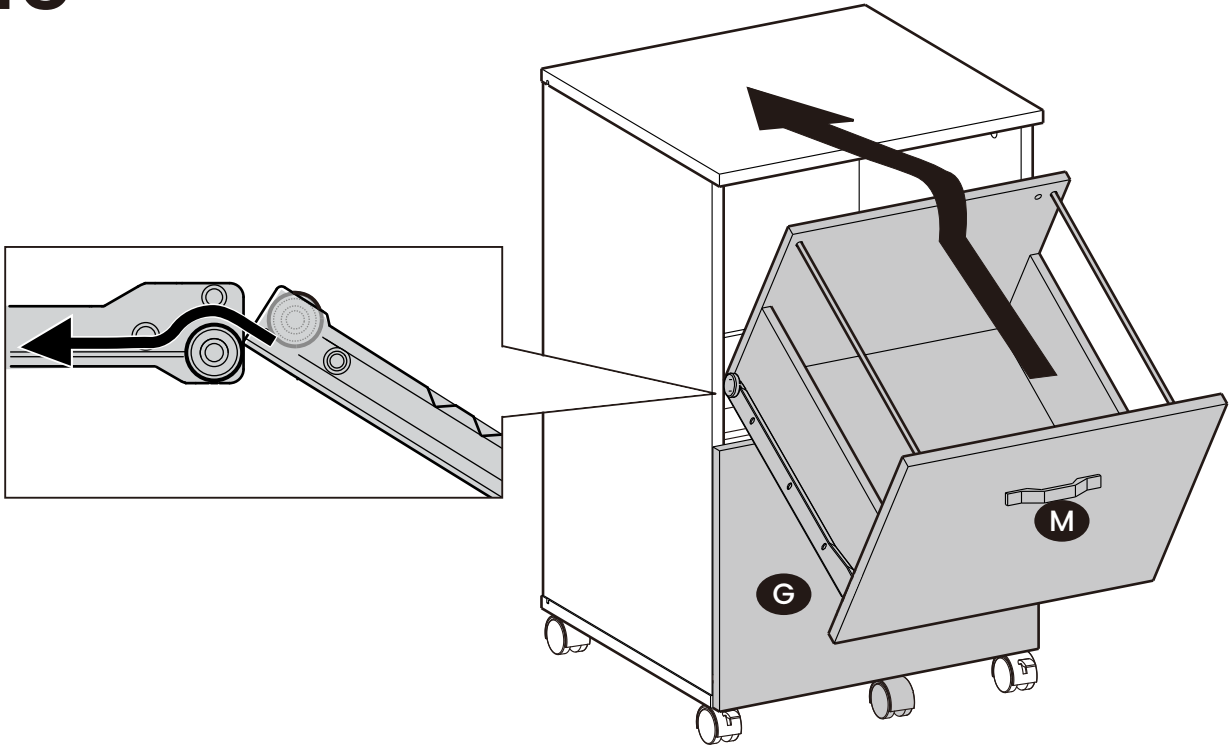

# 27

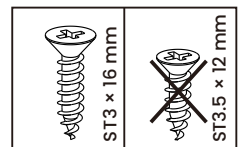
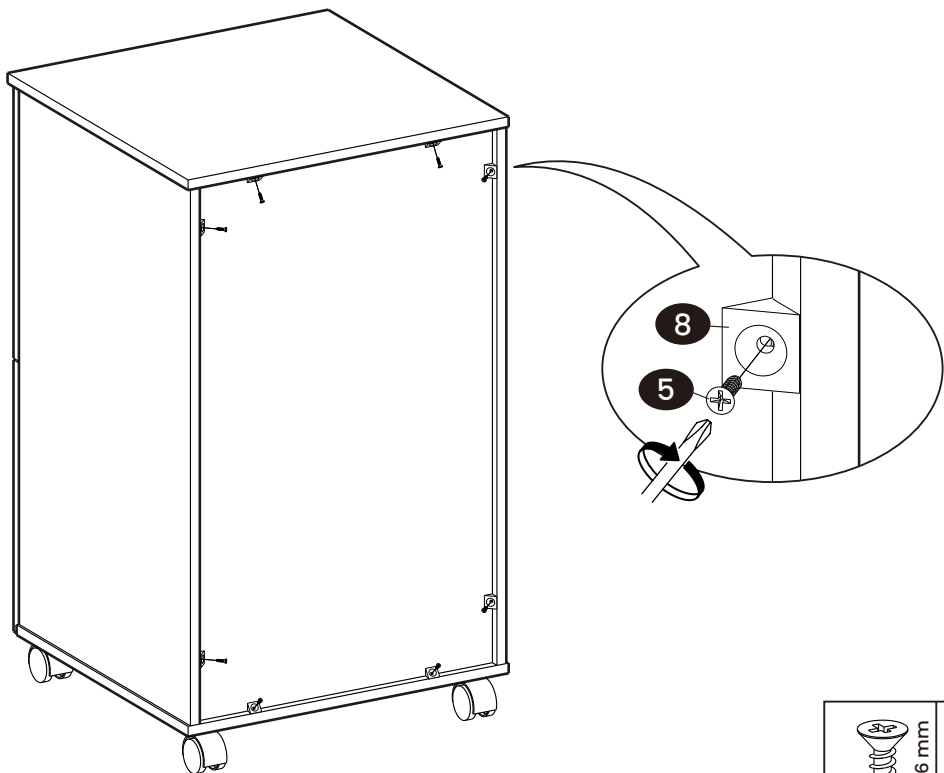

5		x 8	8		x 8
---	---	-----	---	---	-----

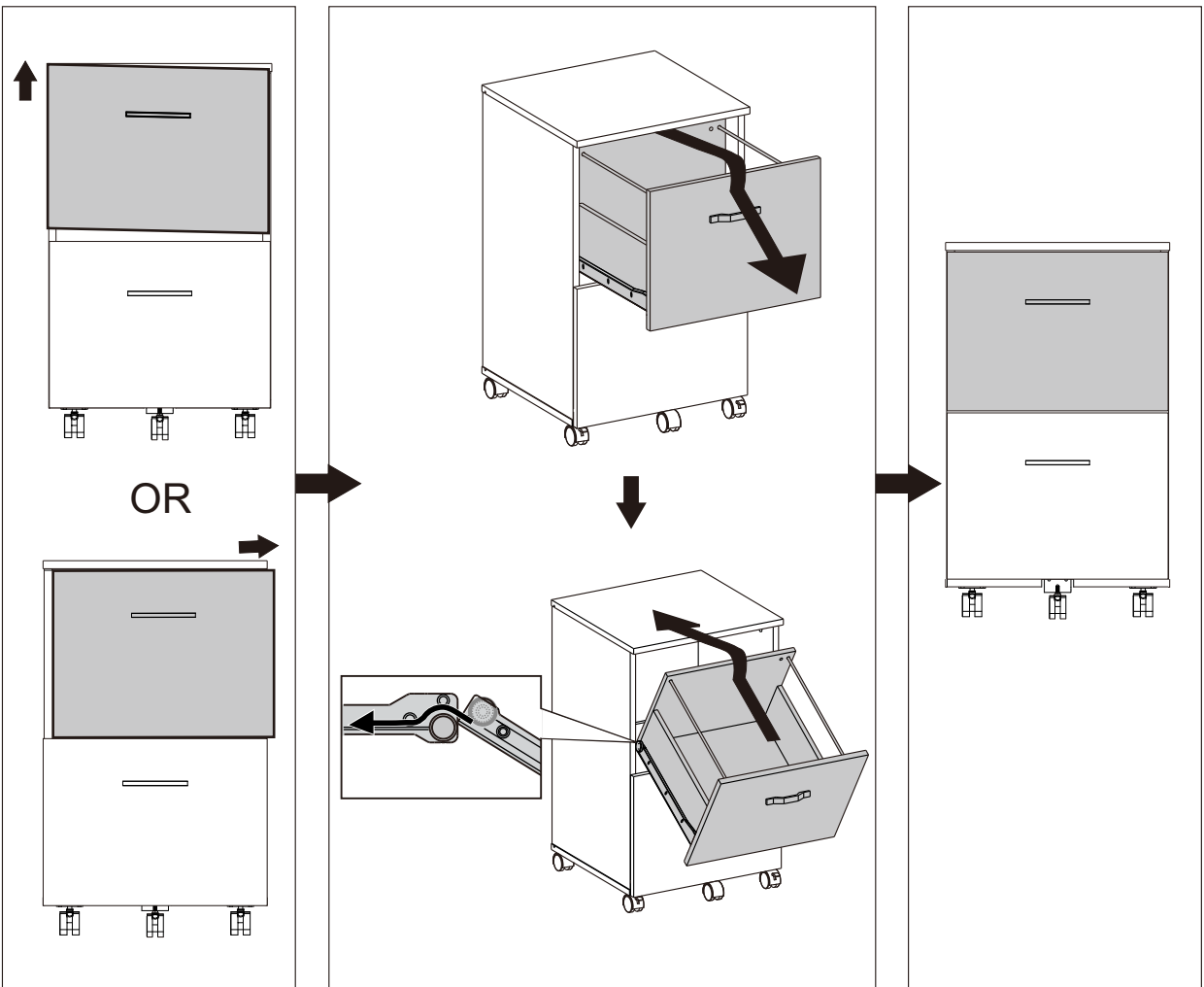
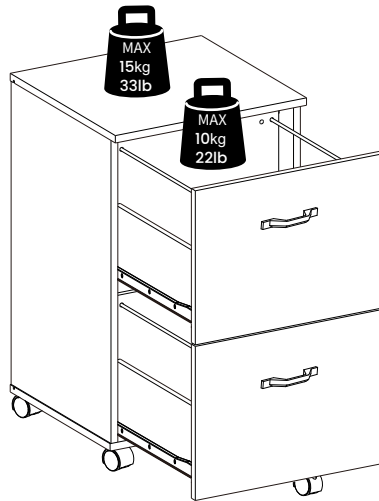



## WARNING/WARNHINWEISE/AVERTISSEMENTS/ATTENZIONE ADVERTENCIA/WAARSCHUWING/VARNING/OSTRZEŻENIE/UYARI

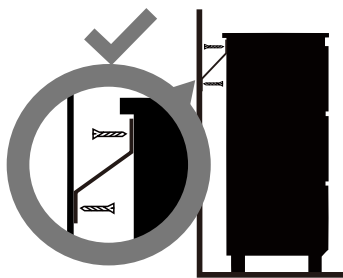

### EN

- Children have died from furniture tipover.
- ALWAYS secure furniture with an anchoring device.
- NEVER allow children to stand, climb, or hang on drawers, doors, or shelves.
- NEVER open more than one drawer at a time.
- Place heavy items down low.
- NEVER place a TV on this furniture.



### IT

- Il rovesciamento dei mobili può essere fatale per i bambini.
- ASSICURARE SEMPRE i mobili con un dispositivo di ancoraggio.
- NON permettere MAI ai bambini di stare in piedi, arrampicarsi o appendersi a cassetti, ante o ripiani.
- NON aprire MAI più di un cassetto alla volta.
- Posizionare gli oggetti pesanti in basso.
- NON posizionare MAI una TV su questo mobile.



### SE

- Våltrisker för möbler kan vara dödliga för barn.
- SÅKRA ALLTID möbler med ett förankringssystem.
- LÅT ALDRIG barn stå, klättra eller hänga på lådor, dörrar eller hyllor.
- ÖPPNA ALDRIG mer än en låda åt gången.
- Placera tunga föremål lågt.
- PLACERA ALDRIG en TV på denna möbel.

### DE

- Beim Umkippen von Möbeln besteht Lebensgefahr für Kinder.
- Sichern Sie die Möbel IMMER mit Kippschutz.
- Kinder dürfen NICHT auf den Schubladen, Türen und Regalen stehen, klettern oder lehnen.
- Öffnen Sie NIEMALS mehr als eine Schublade auf einmal.
- Stellen Sie schwere Gegenstände ganz unten ab.
- Stellen Sie NIEMALS einen Fernseher auf dieses Möbelstück.

### ES

- Los vuelcos de muebles pueden ser mortales para los niños.
- Asegure SIEMPRE el televisor con un dispositivo de anclaje o móntelo en la pared.
- NUNCA permita que los niños se paren, trepen o cuelguen de cajones, puertas o estantes.
- NUNCA abra más de un cajón a la vez.
- Coloque los objetos pesados abajo.
- NUNCA coloque un televisor sobre este mueble.

### PL

- Przechylające się Meble Mogą Być Śmiertelnym Zagrożeniem dla Dzieci.
- ZAWSZE zabezpieczaj meble urządzeniem kotwiczącym.
- NIGDY nie pozwalaj dzieciom stawać, wspinać się lub wieszać na szufladach, drzwiczkach i półkach.
- NIGDY nie otwieraj więcej niż jednej szuflady na raz.
- Ciężkie przedmioty należy umieszczać na dole.
- NIGDY nie umieszczaj telewizora na tym meblu.

### FR

- Le renversement des meubles peut être mortel pour les enfants.
- TOUJOURS fixer les meubles avec un dispositif anti-basculement.
- NE JAMAIS laisser les enfants se tenir debout, grimper ou s'accrocher aux tiroirs, portes ou étagères.
- NE JAMAIS ouvrir plus d'un tiroir à la fois.
- Placez les objets lourds en bas.
- NE JAMAIS placer une télévision sur ce meuble.

### NL

- Omvallende Meubels Kunnen Fataal Zijn voor Kinderen.
- Maak meubels ALTIJD vast met een vastzetapparaat.
- LAAT kinderen NOOIT staan, klimmen of hangen aan lades, deuren of planken.
- OPEN NOOIT meer dan één lade tegelijk.
- Plaats zware voorwerpen beneden.
- Zet NOOIT een tv op dit meubelstuk.

### TR

- Mobilya Devrilmeleri Çocuklar İçin Ölümcül Olabilir.
- Mobilyaları HER ZAMAN bir sabitleme cihazıyla sabitleyin.
- Çocukların çekmecelere, kapılara veya raflara ayakta durmasına, tırmanmasına veya asılmasına ASLA izin vermeyin.
- ASLA aynı anda birden fazla çekmece açmayın.
- Ağır eşyaları aşağıya yerleştirin.
- Bu mobilyanın üzerine ASLA TV koymayın.

## EN Warnings

Children are not allowed to assemble the product. During assembly, keep all small parts out of the reach of children as they may be fatal if swallowed or inhaled.

Children are forbidden to climb or play on the product to avoid serious bodily injury caused by the toppling.

Installation shall be carried out exactly according to the manufacturer's instructions; otherwise, a safety risk can occur if incorrectly installed.

If there are any defective or missing parts after unpacking, cease assembly immediately and contact us. Unauthorized change and modification may affect safety.

## DE Warnhinweise

Kinder dürfen das Produkt nicht aufbauen. Bewahren Sie während der Montage alle Kleinteile außerhalb der Reichweite von Kindern auf. Verschlucken oder Einatmen kann tödlich sein.

Kinder dürfen nicht auf das Produkt klettern oder damit spielen, um schwere Verletzungen durch Umkippen zu vermeiden.

Bauen Sie das Produkt exakt nach Anleitung auf, um Risiken aufgrund fehlerhafter Installation zu vermeiden.

Sollten nach dem Auspacken ein oder mehrere Teile beschädigt sein und/oder fehlen, brechen Sie bitte die Montage sofort ab und setzen Sie sich mit uns in Verbindung. Unbefugte Änderungen und Modifikationen können die Sicherheit beeinträchtigen.

## FR Avertissements

Il est interdit aux enfants d'assembler le produit. Pendant l'assemblage, gardez toutes les petites pièces hors de la portée des enfants car elles peuvent être mortelles en cas d'ingestion ou d'inhalation.

Il est interdit aux enfants de grimper ou de jouer sur le produit pour éviter de graves blessures corporelles causées par le renversement.

Veuillez installer le produit en suivant strictement les instructions du fabricant. Une installation incorrecte peut entraîner un risque pour la sécurité.

En cas de pièces défectueuses ou manquantes après le déballage, arrêtez immédiatement l'assemblage et contactez-nous. Tout changement ou modification non autorisé peut affecter la sécurité.

## IT Avvertenze

I bambini non sono autorizzati a montare il prodotto. Durante il montaggio, tenere tutte le piccole parti fuori dalla portata dei bambini poiché potrebbero essere fatali se ingerite o inalate.

È vietato ai bambini arrampicarsi o giocare sul prodotto per evitare gravi lesioni corporee causate dal ribaltamento.

L'installazione deve essere eseguita esattamente secondo le istruzioni del produttore, altrimenti può verificarsi un rischio per la sicurezza in caso di installazione errata.

Se dopo aver aperto la confezione ci sono parti difettose o mancanti, interrompere immediatamente il montaggio e contattarci. Modifiche non autorizzate possono compromettere la sicurezza.

## ES Advertencias

No está permitido que los niños monten el producto. Durante el montaje, mantenga todas las piezas pequeñas fuera del alcance de los niños, ya que pueden ser mortales si se ingieren o inhalan.

Se prohíbe a los niños trepar o jugar sobre el producto para evitar lesiones corporales graves causadas por el vuelco.

La instalación debe realizarse siguiendo exactamente las instrucciones del fabricante; de lo contrario, puede producirse un riesgo para la seguridad si se instala incorrectamente.

Si hay alguna pieza defectuosa o falta alguna pieza después de desembalar, interrumpa el montaje inmediatamente y póngase en contacto con nosotros. Los cambios y modificaciones no autorizados pueden afectar a la seguridad.

## NL Waarschuwingen

Kinderen mogen het product niet monteren. Houd tijdens de montage alle kleine onderdelen buiten het bereik van kinderen, omdat deze dodelijk kunnen zijn als ze worden ingeslikt of ingeademd.

Kinderen mogen niet op het product klimmen of ermee spelen om ernstig lichamelijk letsel door omvallen te voorkomen.

Installatie dient exact volgens de instructies van de fabrikant te worden uitgevoerd, anders kan er bij onjuiste installatie een veiligheidsrisico ontstaan.

Als er defecte of ontbrekende onderdelen zijn na het uitpakken, stop dan onmiddellijk met monteren en neem contact met ons op. Ongeautoriseerde wijzigingen kunnen de veiligheid beïnvloeden.

## SE Varningar

Barn får inte montera produkten. Under montering ska alla små delar hållas utom räckhåll för barn, eftersom de kan vara dödliga om de sväljs eller inandas.

Barn får inte klättra eller leka på produkten för att undvika allvarliga kroppsskador orsakade av omkullväring.

Installation ska utföras exakt enligt tillverkarens anvisningar, annars kan en säkerhetsrisk uppstå vid felaktig installation.

Om det finns defekta eller saknade delar efter upppackning, avbryt omedelbart monteringen och kontakta oss. Obehöriga ändringar kan påverka säkerheten.

## PL Ostrzeżenia

Dzieciom nie wolno montować produktu. Podczas montażu należy trzymać wszystkie drobne elementy poza zasięgiem dzieci, ponieważ mogą być śmiertelne w przypadku połknięcia lub wdychania.

Dzieciom zabrania się wspinania się lub zabawy na produkcie, aby uniknąć poważnych obrażeń ciała spowodowanych przewróceniem się.

Montaż powinien być przeprowadzony dokładnie zgodnie z instrukcją producenta, w przeciwnym razie w przypadku nieprawidłowego montażu może wystąpić ryzyko dla bezpieczeństwa.

Jeśli po rozpakowaniu są jakiegokolwiek wadliwe lub brakujące części, natychmiast przerwij montaż i skontaktuj się z nami. Nieautoryzowane zmiany mogą wpłynąć na bezpieczeństwo.

## TR Uyarılar

Çocukların ürünü monte etmesine izin verilmez. Montaj sırasında, tüm küçük parçaları çocukların erişemeyeceği bir yerde tutun; yutulması veya solunması halinde ölümcül olabilirler.

Çocukların ürüne tırmanması veya üzerinde oynaması yasaktır; devrilme sonucu ciddi bedensel yaralanmaları önlemek için.

Kurulum, üretici talimatlarına tam olarak uygun şekilde yapılmalıdır; aksi takdirde yanlış montaj durumunda güvenlik riski oluşabilir.

Kutu açıldıktan sonra herhangi bir parça eksik veya kusurluysa, montaja hemen ara verin ve bizimle iletişime geçin. Yetkisiz değişiklikler güvenliği etkileyebilir.

## JP 安全警告メッセージ

ボルトなどの小部品は、お子様が誤って飲み込む事により、窒息などの重大事故を引き起こす恐れがありますので、お子様がいらない場所で組立を行ってください。

転倒による重傷を避けるため、製品に登ったり遊んだりすることは禁止されています。

ご使用前に本書をよくお読みになり、内容を理解された上で、ご使用くださいますようお願い致します。

開封時に部品の欠品・不良があった場合は、直ちに組立を中止し当社までご連絡ください。無断改造は安全性低下の原因となります。

販売元: ZIELJP株式会社 〒531-0062 大阪市北区長柄中3丁目6番13号

TEL: 06-7161-1020 メール: info\_jp@songmics.jp

## AR

## تحذيرات

يُمنع الأطفال من تجميع المنتج. أثناء التجميع، يُرجى إبقاء جميع الأجزاء الصغيرة بعيداً عن متناول الأطفال، فقد تكون مميتة إذا تم ابتلاعها أو استنشاقها.

يُحظر على الأطفال تسلق المنتج أو اللعب به، لتجنب الإصابة الجسدية الخطيرة الناتجة عن انقلابه.

يجب تنفيذ التركيب بدقة تامة وفقاً لتعليمات الشركة المصنّعة، حيث إن أي خطأ في التركيب قد يؤدي إلى مخاطر تتعلق بالسلامة.

إذا وُجدت أي أجزاء تالفة أو مفقودة بعد فتح العبوة، توقف عن التجميع فوراً واتصل بنا. قد تؤثر التعديلات أو التغييرات غير المصرح بها على السلامة.

## PT Avisos de Segurança

Crianças não devem montar este produto. Durante a montagem, mantenha todas as peças pequenas fora do alcance de crianças, pois podem ser fatais se ingeridas ou inaladas.

É proibido que crianças subam ou brinquem sobre o produto, a fim de evitar ferimentos graves causados por tombamento.

A instalação deve ser realizada estritamente conforme as instruções do fabricante, pois a montagem incorreta pode representar risco à segurança.

Caso identifique peças defeituosas ou ausentes após abrir a embalagem, interrompa a montagem imediatamente e entre em contato conosco. Modificações ou alterações não autorizadas podem comprometer a segurança do produto.

## KR 경고사항

어린이는 제품을 조립할 수 없습니다. 조립 중에는 모든 작은 부품들어린이의 손이 닿지 않는 곳에 보관하십시오. 삼키거나 흡입할 경우 치명적일 수 있습니다.

어린이가 제품에 오르거나 놀지 못하도록 하십시오. 제품이 넘어질 경우 심각한 신체 상해를 입을 수 있습니다.

설치는 제조업체의 지침에 따라 정확하게 수행되어야 합니다. 그렇지 않으면 잘못 설치될 경우 안전 위험이 발생할 수 있습니다.

개봉 후 결함이 있거나 누락된 부품이 있는 경우 즉시 조립을 중단하고 당사에 연락하십시오. 무단 변경 및 수정은 안전에 영향을 미칠 수 있습니다.

## CS Varování

Dětem není dovoleno výrobek sestavovat. Při montáži mějte všechny malé součástky mimo dosah dětí, protože by mohly být nebezpečné při polknutí nebo vdechnutí.

Dětem je zakázáno lézt nebo si na výrobku hrát, aby se zabránilo vážnému poranění způsobenému převrácením.

Montáž musí být provedena přesně podle pokynů výrobce, jinak může při nesprávné instalaci dojít k bezpečnostnímu riziku.

Pokud po vybalení zjistíte chybějící nebo poškozené díly, okamžitě přestaňte s montáží a kontaktujte nás. Nepovolené úpravy a změny mohou ovlivnit bezpečnost.

